

---

**URSA** MINERAL WOOL  
Party Wall Thermal Bypass Solutions

---

Insulation for Masonry & Timber  
Frame Cavity Separating Walls



# The Company

As a leading supplier of insulation and insulating systems, **URSA** has succeeded in fully addressing user requirements for thermal and acoustic insulation. Quality products for every application and excellent customer support are the cornerstones of the corporate culture.

**URSA** is the number two manufacturer of glass wool and extruded polystyrene products in Europe. At 13 production sites, **URSA** has 2,000 employees generating sales revenues of over €500 million.

**URSA mineral wool** is manufactured in Spain, France and Belgium, at two sites **URSA** has in Germany, in Slovenia, Hungary and Poland as well as in two Russian plants. Our closely-woven network of sales offices stretches across Europe and Russia. Almost everywhere **URSA** is amongst the market leaders.

In Russia and in a number of other Eastern European countries, we are number one in the glasswool segment. We have also enjoyed a strong position particularly on the growth markets of the new EU partner countries from the very beginning.

- Headquarters
- Branch
- Production site mineral wool
- Production site extruded polystyrene



---

# URSA

## Party Wall Thermal Bypass Solutions

---

URSA has a range of glass mineral wool products for use in both masonry and timber frame cavity separating walls including **URSA TF Roll**, **URSA TF Slab**, **URSA Acoustic Roll**, **URSA Party Wall Roll** and **URSA Cavity Batts**.

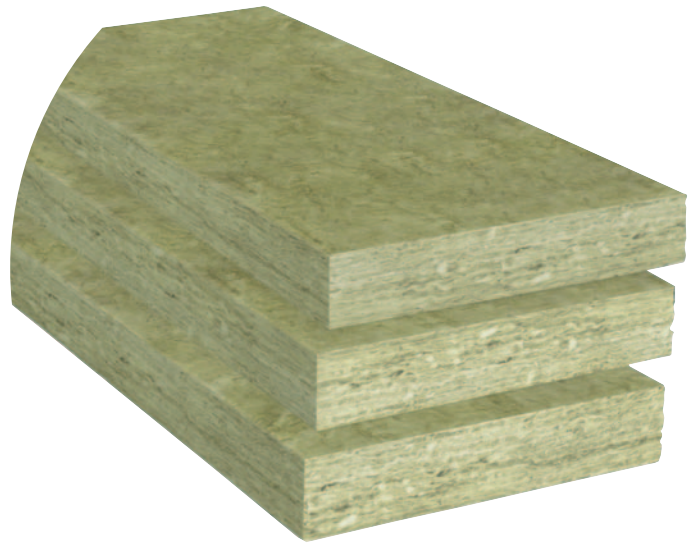

## Benefits

### Party wall heat loss

**URSA TF Roll**, **URSA TF Slab**, **Acoustic Roll**, **Party Wall Roll** and **Cavity Batt** products will help to eliminate the heat loss at party walls and also offer an enhanced acoustic performance.

### Acoustic

URSA mineral wool products have excellent sound insulation characteristics to help meet the Building Regulation and Robust Details, Part E, requirements.

### User friendly

Our new generation URSA TERRA mineral wool has a 'soft touch' feel making it easier to handle and install whilst still maintaining its excellent mechanical properties.

### Environment

URSA mineral wool is manufactured from an abundant, sustainable resource and utilises at least 50% glass waste.

### Quality

Outstanding product quality manufactured to ISO 9001 Quality Systems.

### Global warming potential

URSA mineral wool products do not use chemical blowing agents and so the Global Warming Potential (GWP) arising from them is zero.

### Handling

URSA mineral wool products are lightweight yet tough, resilient and easy to install. They are easily cut using a sharp knife.

### Durability

URSA mineral wool products are rot-proof, durable and maintenance free. They are non-hygroscopic and will not slump in normal use.

All of our products carry the CE Mark to show compliance with the harmonised European Standard BS EN 13162 and are quality assured to ISO 9001.



# Design

## Party Wall Heat Loss

Traditionally the heat loss through separating/party cavity walls in semi detached and terraced properties was assumed to be zero as, in theory, there is no temperature differential across the wall. Studies have shown however that air movement within this cavity (with further infiltration from the front and rear external cavity walls) means the separating wall can have an equivalent U-value as high as 0.70 W/m<sup>2</sup>K.

The Building Regulations now recognise the importance of the party wall thermal bypass and measures must be taken to reduce its effect. The studies have identified two important measures;

- Fully filling the cavity with glass wool insulation with a **minimum density of 18 kg/m<sup>3</sup>**.
- Installing adequate edge sealing at all exposed edges and in line with the insulation in adjacent elements.

For optimum performance the party wall cavity insulation and the edge sealing must be contiguous. These measures will reduce the heat flow through, across and along the separating wall and reduce air movement into and within the wall. Done correctly they will reduce the U-value of the wall to zero.

Effective edge sealing alone will reduce the effective U-value to 0.20 W/m<sup>2</sup>K.

## Workmanship

The insulation must fully fill the masonry party wall cavity so that it is in effective\* contact with both masonry faces of the cavity up to the underside of the roof line. All joints must be tightly butted without gaps or voids.

Mineral wool filled sleeved flexible cavity barriers shall be installed at the vertical edges of the party wall cavity with the cavity barrier in contact with the insulation fill in the cavity.

All joints shall be tightly butted to ensure a continuous barrier at the junction of the party wall and external wall. This provides an effective edge seal when used in conjunction with full fill mineral wool insulation as described above.

\*Effective means that the insulation must be in contact with the face of both masonry leaves. It is allowable for contact to be broken in strictly limited localised areas for example where voids in mortar joints occur or where mortar protrudes into the cavity and locally compresses the insulation.

The quality of workmanship must be carefully monitored and be part of the on-site quality control process. The quality control system should highlight those aspects of the process that are critical to performance.

For example, highlighting the need to use cavity boards and to clear mortar from the top of the slabs or rolls during construction so that this reduces the risk of gaps at joints.

Installers should carefully follow the design guidelines contained in this brochure, the MIMA Design Guide on preventing thermal bypass, BBA certificates etc. Also consider the use checklists and additional on-site training.

Figure 1

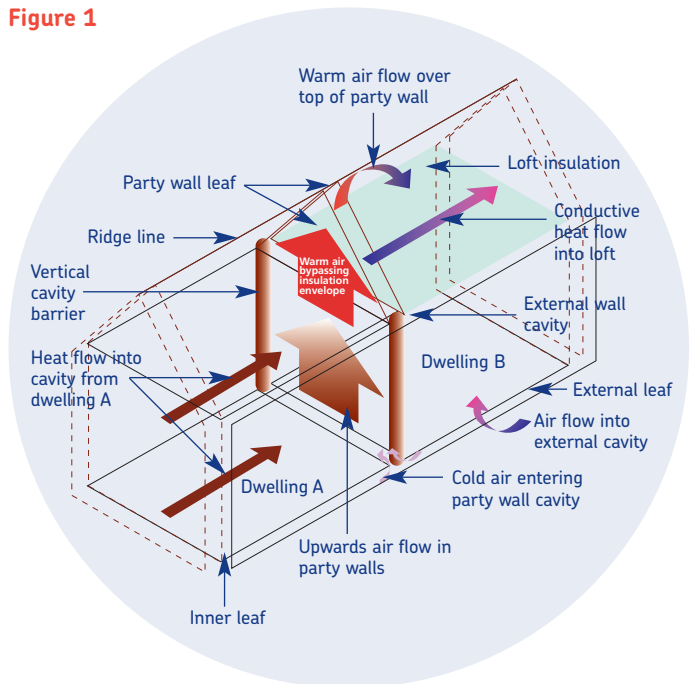

## Acoustics

Masonry cavity and timber frame separating walls must provide suitable sound insulation between dwellings as outlined in Approved Document E of the Building Regulations (Section 5 in Scotland). Suitable details have been used successfully for many years; adding further layers of insulation into the walls must not degrade this performance. Extensive testing has been undertaken to show that the use of glass mineral wool fully filling any cavities does not degrade the performance. The Building Regulations, Part E Robust Details and MIMA document Preventing Thermal Bypasses in Party Separating Walls show suitable solutions and detailed drawings.

URSA mineral wool products are covered by a number of Robust Details for both parged and unparged masonry walls and timber framed walls.

## Fire Performance

URSA mineral wool products are classed as non-combustible and will not prejudice the fire resistance properties of the wall.

# Installation

## Cavity Masonry Separating Walls (Figure 2)

**URSA Cavity Batt/URSA Party Wall Roll** is built in as the wall is constructed.

The insulation must be installed so that it will fully fill the cavity and be in contact with both sides of the cavity, ensure that:

- Any resultant small voids do not interconnect; and
- Any such voids are not so extensive as to provide an air path between external wall cavities and/or floor, roof and intermediate floor cavities.

A suitable cavity stop sock is used at the junction of the party wall and external wall when using partial fill insulation in the external wall.

### The usual procedure for construction is;

1. The party wall may be built leading with either leaf; a minimum 75mm cavity must be maintained.
2. The first row of **URSA Cavity Batts/URSA Party Wall Roll**, cut to size if necessary, may begin below the DPC in order to ensure continuity of insulation.
3. Raise the leading leaf to the level of the next row of wall ties, normally at 450mm vertical centres. Excess mortar should be cleaned from this leaf before fitting the insulation onto the lower ties.
4. The next row of wall ties is fitted to retain the top of the insulation. Ensure that the drip is positioned at the centre of the insulation.
5. The other leaf is then built to the level of the top of the **URSA Cavity Batts/URSA Party Wall Roll** and the process repeated.
6. The subsequent rows of insulation should be fitted with vertical joints staggered i.e. brick bond with all joints tightly butted. Insulation with damaged edges or corners should not be used.
7. As work proceeds ensure that the top of the insulation is kept clean and free from mortar droppings. The use of a cavity batten will help to protect the insulation as the next section is built.
8. Cut sections of insulation may be required at corners and at the junction with the external wall. It is essential that these be cut accurately to fill the space they are intended for.
9. Ensure that partially completed walls are protected from inclement weather (wind, rain and snow) and at the end of the day's work.

Figure 2

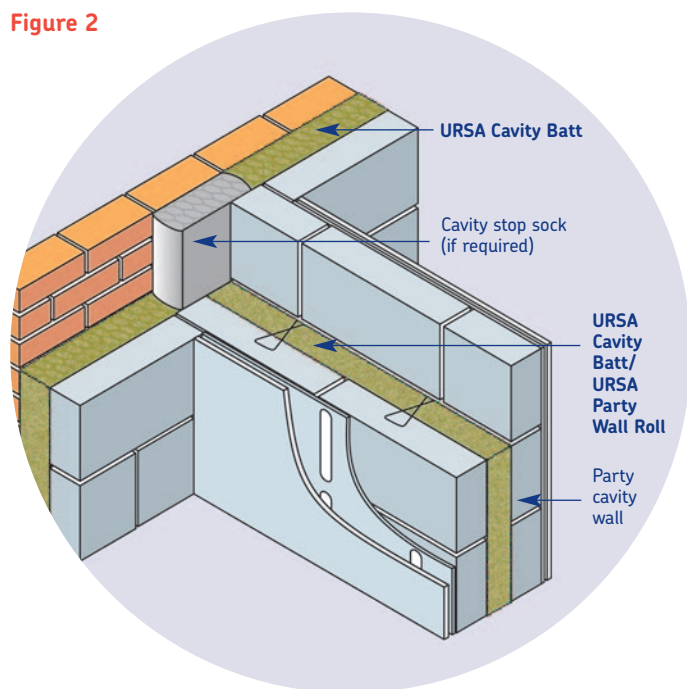

# Installation

## Timber Frame Separating (Party) Walls (see Figures 3 & 4)

The additional heat loss due to thermal bypass in timber frame party/separating walls must now be accounted for in the overall thermal assessment of the building. Fully filling the interstud and interframe voids with mineral wool along with efficient edge sealing can reduce the effective heat loss to 0.00 W/m<sup>2</sup>K.

**URSA TF Roll**, **URSA TF Slab** and **URSA Acoustic Roll** are designed to fit between the studs in each wall and between each leaf.

### The usual procedure for construction is:

1. Fit the timber frame walls in the normal manner and in accordance with the manufacturer's details ensuring a minimum of 240mm between the inner faces of the wall linings and 50mm separation between the studs in each leaf. If, for structural reasons, a sheathing board is used on one or both leaves ensure a 50mm gap is maintained between the panels.
2. Install **URSA Acoustic Roll** between the frames. High tack spray adhesive may be used to secure the insulation to one of the leaves when using plywood sheathing. Account for on-site tolerances and ensure the space is fully filled across the whole wall area.
3. Install **URSA TF Roll** or **URSA TF Slab** in **both** frames filling the full depth of the studs.
4. Install vertical cavity barriers to seal the cavity (for acoustic, thermal and fire performance) ensuring that they are contiguous with the party cavity wall insulation.
5. Ensure that partially completed walls are protected from inclement weather (wind, rain and snow) and at the end of the day's work.

Figure 3 – Timber Frame Separating Wall

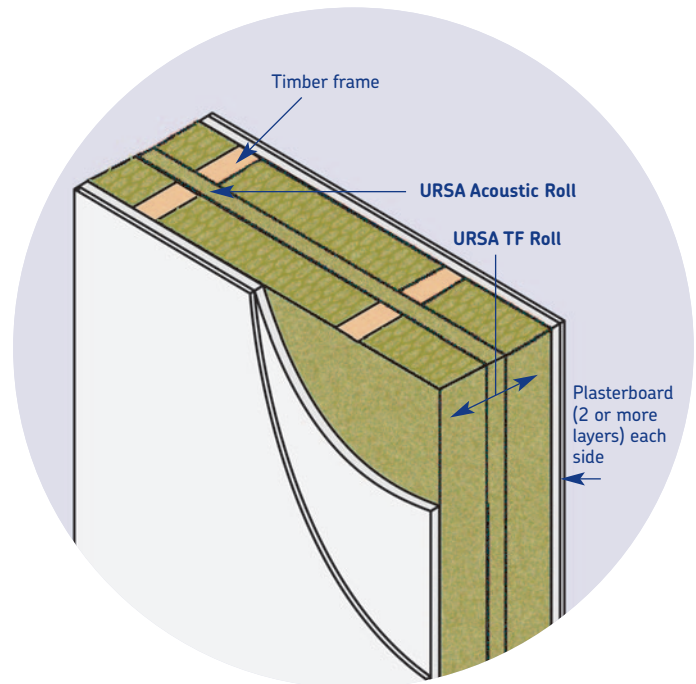
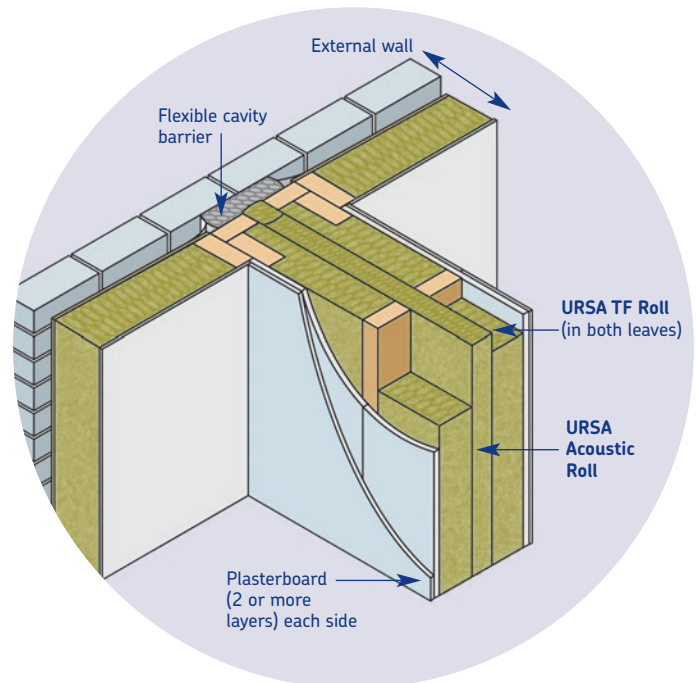
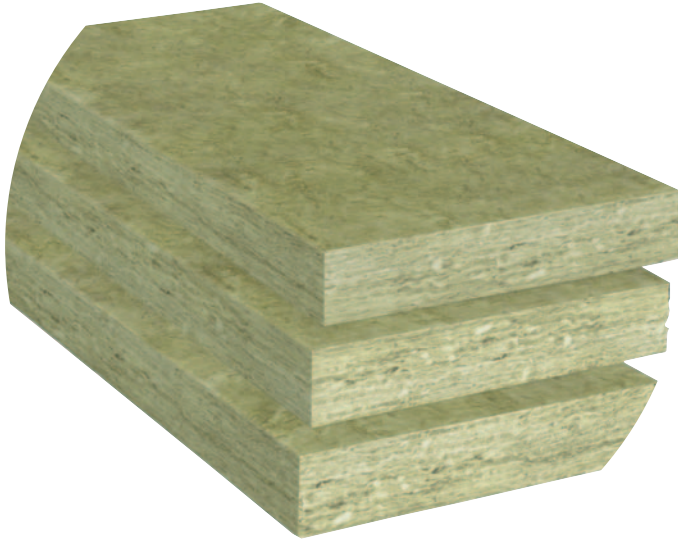

Figure 4 – Timber Frame Separating/External Wall Junction



# Technical Details



## URSA Cavity Batt 35

### Thermal Conductivity

The declared thermal conductivity is 0.035 W/mK when tested to BS EN 13162.

### Density

Nominal density is 22 kg/m<sup>3</sup>.

### Reaction to Fire

Euroclass A1 to BS EN 13501-1.

### Designation Code

MW – EN 13162 – T4 – DS(70,-) – WS.

## URSA Cavity Batts

Dimensions		
Thickness (mm)	Length (mm)	Width (mm)
75, 100 & 125	1200	455

## URSA Party Wall Roll

### Thermal Conductivity

The declared thermal conductivity is 0.035 W/mK when tested to BS EN 13162.

### Density

Nominal density is 22 kg/m<sup>3</sup>.

### Reaction to Fire

Euroclass A1 to BS EN 13501-1.

### Designation Code

MW – EN 13162 – T2 – DS(70,-) – MU1 – Afr5.

## URSA Party Wall Roll

Dimensions		
Thickness (mm)	Length (mm)	Width (mm)
100	6000	455

# Technical Details

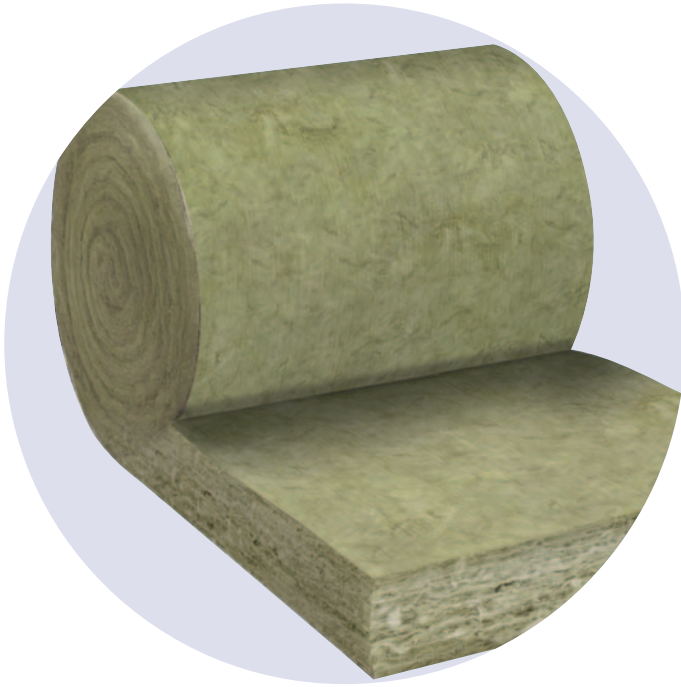

## URSA TF Roll 35

### Thermal Conductivity

The declared thermal conductivity is 0.035 W/mK when tested to BS EN 13162.

### Density

Nominal density is 22 kg/m<sup>3</sup>.

### Reaction to Fire

Euroclass A1 to BS EN 13501-1.

### Designation Code

MW – EN 13162 – T2 – DS(70,-) – MU1 – AFR5.

## URSA TF Roll 35

Dimensions	
Thickness (mm)	Width (mm)
90 & 140	2 x 570

### Moisture Vapour Transmission

URSA mineral wool products have a minimal resistance to the passage of water vapour thus allowing the wall to breathe.

A practical value for the moisture vapour resistivity is 5 MNs/gm.

### Specific Heat Capacity

The specific heat capacity is 1.03 kJ/kgK.

### Environmental Information

#### BRE Green Guide

All URSA mineral wool products achieve the best possible 'A+' rating under the BRE Green Guide.

Manufactured to BS EN ISO 14001.

## URSA Acoustic Roll

### Thermal Conductivity

The declared thermal conductivity is 0.035 W/mK when tested to BS EN 13162.

### Density

Nominal density is 22 kg/m<sup>3</sup>.

### Reaction to Fire

Euroclass A1 to BS EN 13501-1.

### Designation Code

MW – EN 13162 – T2 – DS(70,-) – MU1 – AFR5.

## URSA Acoustic Roll

Dimensions	
Thickness (mm)	Width (mm)
25*, 50, 60, 75 & 100	2 x 600 (*also 1200)





# Technical Details

## **Durability**

When correctly installed, URSA mineral wool products are maintenance free and have an indefinite life at least equal to that of the building.

## **Storage**

URSA mineral wool products are supplied wrapped in polythene to provide short-term protection. On site the products should be stored clear of the ground, on a clean level surface and preferably under cover to protect them from prolonged exposure to moisture or mechanical damage.

## **Chemical Compatibility**

URSA mineral wool products are compatible with all common construction materials, alkalis, dilute acids, mineral oil and petrol. Products that have been in contact with harsh solvents, acids or saturated with water should not be used.

## **Health and Safety**

URSA mineral wool products are inherently safe to handle. During cutting or handling any dust generated is of nuisance value only; the wearing of dust masks, gloves and long sleeved clothing is recommended. Large scale machining should be connected to a dust extraction system.

A comprehensive Health and Safety data sheet is available from URSA UK Ltd upon request.

## **Availability**

URSA mineral wool products are available nationally through insulation distributors and builders merchants.

## **References**

The Building Regulations and supporting documents.

Preventing Thermal Bypasses in Party Separating Walls (MIMA).

Robust Details Part E (Robust Details Ltd).

Accredited Construction Details and Accredited Construction Details (Scotland).

CIBSE Guide A3 - Thermal Properties of Buildings and Components.

BBA Certificate No. 09/4624 (**URSA Cavity Batt**).

BRE Digests, Information Papers and Good Building Guides.

URSA UK LTD  
Crest House  
102-104 Church Road  
Teddington, Middlesex TW11 8PY  
United Kingdom

Tel : 020 8977 96 97  
Fax : 020 8977 94 56

Web : [www.ursa-uk.co.uk](http://www.ursa-uk.co.uk)  
E-mail : [ursauk@ursa.com](mailto:ursauk@ursa.com)

